



CLL 150W

FEATURES

- Special use for Light box/Light box advertising
- Double-Sided Boards Design(PCB)
- 100% full load burn-in test, Universal AC input
- Slim design, small size and high efficiency
- Built-in EMI filter with tiny ripple
- Protection: short circuit/over current/over load/over temperature
- 2 years warranty

MODEL		CLL150-W1V12	CLL150-W1V24
OUTPUT	DC VOLTAGE	12V	24V
	VOLTAGE TOLERANCE	±5%	±5%
	RATED CURRENT	12.5A	6.25A
	CURRENT RANGE	0-12.5A	0-6.25A
	RATED POWER	150W	150W
	RIPPLE & NOISE (MAX.)	100mVp-p	120mVp-p
	POWER FACTOR(Typ.)	0.6	0.6
INPUT	VOLTAGE RANGE	100-240VAC	
	FREQUENCY RANGE	50/60 Hz	
	AC CURRENT(Typ.)	2.6A/115V, 1.25A/230V	
	EFFICIENCY(Typ.)	85%	88%
	COLD START CURRENT	40A/AC230V	
	SETUP, RISE, HOLD UP TIME	1500ms, 50ms, 20ms	1500ms, 50ms, 20ms
	NO-LOAD CURRENT	<10mA/240VAC	
PROTECTION	OVER LOAD	hiccup 105%~150% of the rated power 150W, recovers automatically after fault condition is removed	
	OVER CURRENT	hiccup over the maximum rated current, recovers automatically after fault condition is removed	
	SHORT CIRCUIT	hiccup short circuit, recovers automatically after fault condition is removed	
	OVER TEMP	hiccup the Rectifier ≥85°C, recovers automatically after temperature fall to environment temp	
ENVIRONMENT	WORKING TEMP	-20°C~+40°C (no frost)	
	WORKING HUMIDITY	20%~90%RH	
	STORAGE TEMP	-40°C~85°C	
	STORAGE HUMIDITY	10%~95%RH	
SAFETY&EMC	SAFETY STANDARDS	CE, ROHS	
	WITHSTAND VOLTAGE	I/P-O/P: 1.5KVAC/1min, I/P-F/G: 1.5KVAC/1min, O/P-F/G: 0.5KVAC/1min	
	EMC TESTING STANDARD	EN55022:2010; EN61000-3-2:2014; EN61000-3-3:2013; EN55024:2010+A1:2015 EN61347-1:2008+A1:2011+A2:2013; EN61347-2-13:2014	
REMARK	1. The above mentioned data were measured at 220VAC input and 25°C. 2. Ripple & noise are measured at 20MHz of bandwidth by using a 12" twisted pair-wire terminated with a 0.1uf & 47uf parallel capacitor.		

Tel: 086 755 2306 0905

Fax: 086 755 2304 1269

Website: www.szshanpu.cc

Add: 5th Floor, B3 Building, 2nd Nanchang Industrial Park, Xixiang Street, Baoan District, Shenzhen, China

Mechanical Specification

Terminal Assignment			
Pin No.	Assignment	Pin No.	Assignment
1	AC INPUT/L	1	DC OUTPUT/-V
2	AC INPUT/N	2	DC OUTPUT/-V
3	FG	3	DC OUTPUT/+V
		4	DC OUTPUT/+V
Packing and Weight			
Dimension	230*55*21mm	Weight	0.3kg
Carton Dimension	325*245*225mm	Carton weight	0.5kg
Carton quantity	35pcs/carton		

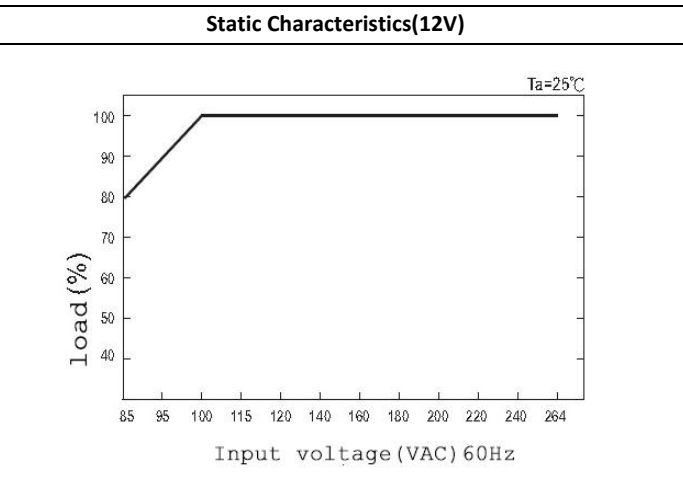
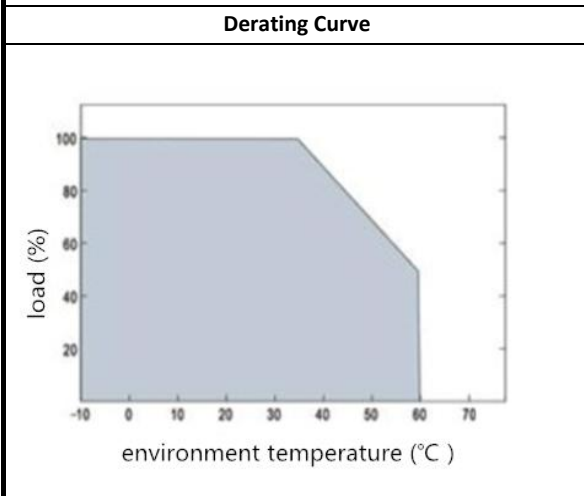
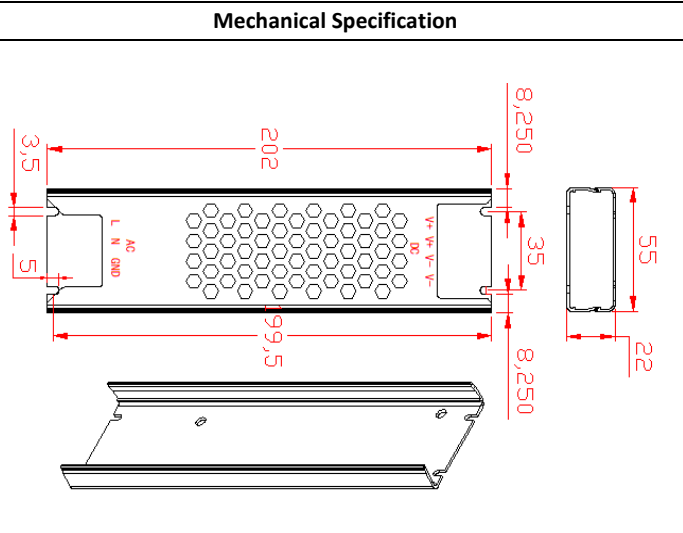

Note

1. Cut the AC input before checking any mal-phenomenons.
2. Make sure the INPUT&OUPUT were in right situation before connected to power supply.
3. Be ware of high power pressure may caused by short circuit when installing metal casing products.
4. All the images and data are just for reference, specific please in kind prevail!

F&Q

A. First use, connect the LEDs to the power supply, correct AC&DC connection, but the LEDs are not light or other fault condition.

Q. Cut the AC input, check whether there are any poor contacts in the AC and DC terminals.

A. Correct connection, the LEDs is on but the brightness is too strong/too weak/flashing.

Q. Cut the AC input, check whether over load or short circuit.